

SHOWS SCRIBE LINE ON RAIL
AT NOMINAL POSITION

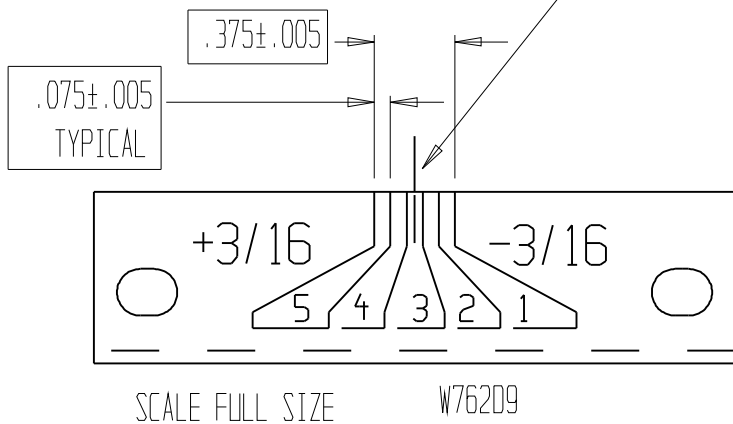

ACCEPTANCE CRITERIA:
RECERTIFICATION TOLERANCE IS +/- .020".
KNOWING THAT SCALE GRADUATIONS HAVE A
LINE WIDTH OF LESS THAN .008". ANY
MEASUREMENT SHOULD BE ON THE APPROPRIATE
LINE OR NOT MORE THAN TWO LINE THICKNESSES
AWAY AS DETERMINED VISUALLY .

RECALIBRATION:
1. VISUALLY CHECK THE GAGE FOR DAMAGE.
2. USE RIGID SCALE TO VERIFY TWO CRITICAL
DIMENSIONS.

BOXED DIMENSIONS ARE MINIMUM
CHARACTERISTICS TO BE VERIFIED
FOR RECERTIFICATION
RECERTIFICATION TOLERANCE +/- .020"
REFERENCE:
AAR D MANUAL M-214

WINCHESTER INDUSTRIES INC.				
PAIRING GAGE 1107-1				
SIZE A	Job#	DWG NO. W762	Disk	REV A
CUSTOMER			ENG DJD 08/20/2007	